



light style

by RUGGIU

Lampade semplici che inneggiano a un abitare moderno.

Oggetti che con discrezione si impongono per l'originalità delle soluzioni formali: inaspettate, spesso ironiche, con solidi riferimenti al classico e una buona parte di giocosità e senso dell'umorismo.

Questa collezione esprime in libertà il vocabolario progettuale dei designer: JoeVelluto (Art Direction Light Style), Odoardo Fioravanti, Giulio Iacchetti e Matteo Ragni. Tutti ben felici di utilizzare un segno vagamente autoreferenziale, eppure rispettoso sia delle aspettative dell'azienda che degli insegnamenti dei grandi maestri del design italiano.

Con un occhio anche all'impegno: il LED è a basso impatto energetico e garantisce allo stesso tempo alta luminosità e durata.

Decorative luminaires characterized by clean design suitable for modern livings.

Sobre, discreet yet original in their lines, often ironic with a vocation for playing, they create a mix between classic and modern with a touch of cool and funny technique.

This collection is a full expression of the designers' activity: JoeVelluto (Art Direction Light Style), Odoardo Fioravanti, Giulio Iacchetti and Matteo Ragni. Four different looks, four designers who have made their proposal mixing creativity and functionality, in the respect of the Company's expectations and the ideas and principles of the great italian design school.

With a particular eye to the most modern technology: the LED is an exciting and booming world of new technology, reducing considerably power consumption and eliminating maintenance and lamp changing.

Light style

Design: Odoardo Fioravanti

MICRO

Se il LED è una piccolissima lampadina perché non pensare a una piccolissima lampada da costruire intorno ad esso? Nasce così la Micro alta come un accendino, grande quanto una mela. È una piccola-grande lampada che racconta un cambio improvviso di scala e di percezione.

If LED is a very small light source, why not create a very small lamp around it? Micro comes out as a result of this premise, not higher than a lighter, as big as an apple. It is a small-big lamp witnessing a sudden change in scale and perception.



4



5



Lampada da tavolo / Table lamp
Materiali: Base in metallo cromato - Diffusore in metacrilato
Materials: Chrome metal base - Methacrylate diffuser

MICRO

Light style

Design: Odoardo Fioravanti

LOFT

Ripensare le forme della classica abat-jour donandole una forma contemporanea. Una riflessione che muove dalla bellezza classica della simmetria per arrivare a un oggetto asimmetrico e perennemente sbilanciato. Loft è una presenza inaspettata, quasi una sorpresa che diventa rapidamente familiare e leggibile. Un personaggio che prende vita illuminandosi e portando luce negli interstizi della casa.

The classic forms of an abat-jour are revisited into contemporary lines. A reflection moving far from the classic beauty of perfect symmetry to arrive at an object with asymmetrical designs eternally unbalanced. Loft is an unexpected presence, almost a surprise which soon becomes friendly. A character becoming animate bringing light into the house.



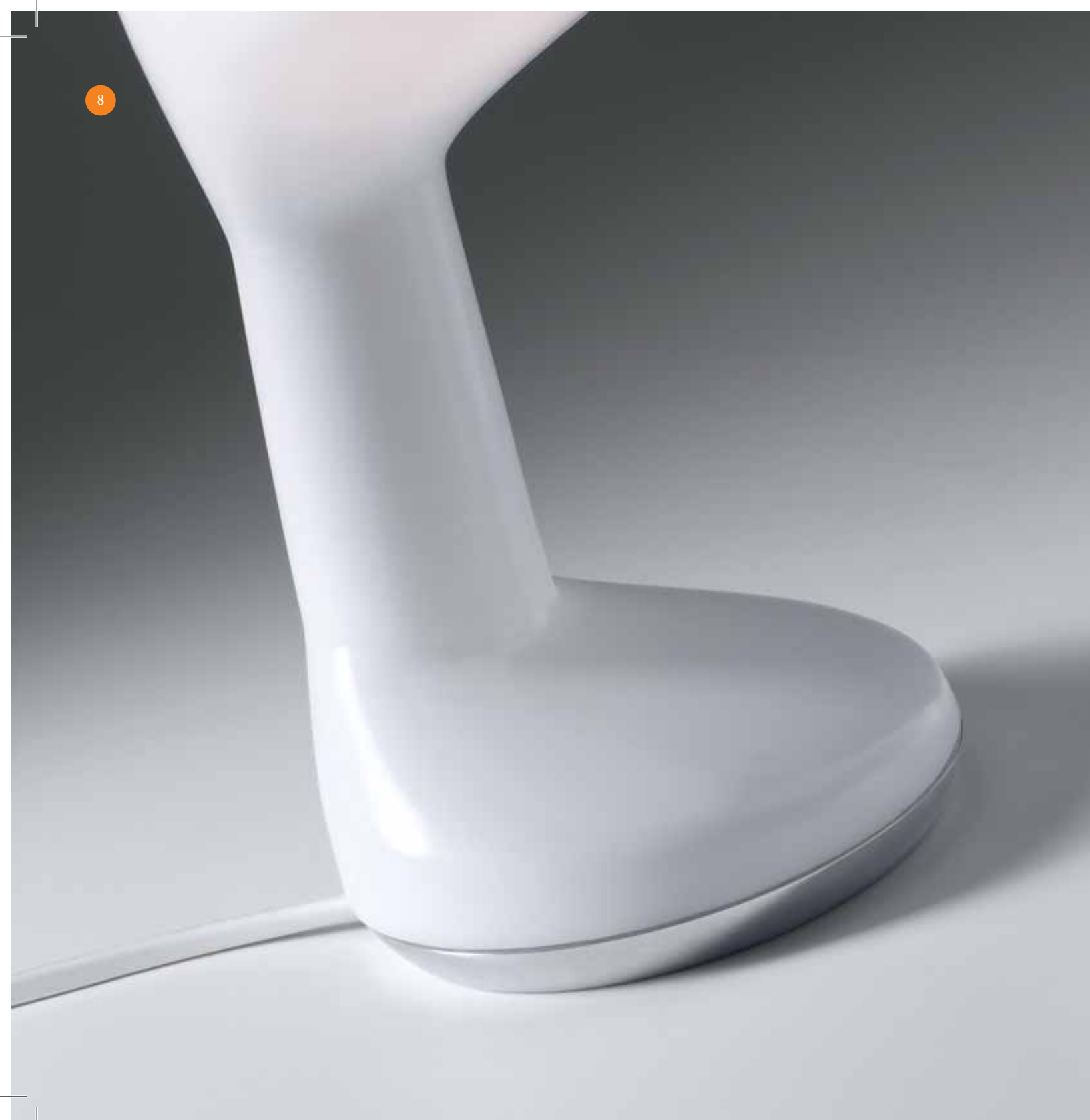

Lampada da tavolo / Table lamp
Materiali: Base in metallo - Diffusore in metacrilato
Materials: Metal base - Methacrylate diffuser

Light style

Design: **Giulio Iacchetti**

SHOWER LIGHT

Shower-Light è una dislocazione di senso. Una doccia che si sposta, che cambia significato, che si fa lampada. Un assurdità?

A quanto pare no, perché l'oggetto ha l'essenzialità di un'eleganza sofisticata e la linea precisa di una forma progettata. Per diventare un nuovo simbolo.

Shower-Light is a revolutionary concept which goes beyond the traditional idea of light. A shower which becomes a luminaire providing amusement and fun. Something totally different from what you would normally expect from a lamp?

Not at all, because sophisticated elegance and rigorous lines are crucial factors. To become a new symbol.





Lampada da terra / *Floor lamp*
Materiali: Metallo cromato
Materials: Chromed metal

SHOWER LIGHT PT



Sopsensione / *Suspension*
Materiali: Metallo cromato
Materials: Chromed metal

SHOWER LIGHT SO



Lampada da tavolo / *Table lamp*
 Materiali: Metallo cromato
 Materials: *Chromed metal*

SHOWER LIGHT LT



Lampada da parete / *Applique*
 Materiali: Metallo cromato
 Materials: *Chromed metal*

SHOWER LIGHT AP

Light style

Design: Joe Velluto

TÊTE À TÊTE

Una cena a lume di candela, l'abito più bello e sensuale, il momento più atteso fievolmente illuminato dalla luce filtrata dalla maliziosità dell'organza nera, tra un sedile dell'auto e il freno a mano.

Tête à tête è una lampada versatile, e può essere collocata ovunque poiché dotata di gancio e presa di alimentazione da 12V per l'accendisigari da macchina. Quando si possiede la comodità delle mura domestiche, può trovare spazio in casa grazie ad un supporto che la trasforma in lampada da tavolo.

A candlelit dinner, a sensual and extravagant dress, the most awaited moment with the light slightly filtering through a malicious black organdie lampshade between the car seat and the handbrake. Tête à tête is a versatile and functional luminaire, whose light head can be moved and placed anywhere thanks to a metal hook and to the 12V supply suitable for car lighters. Yet, it can find proper place in a comfortable house thanks to a device transforming it into a table lamp.





Lampada per auto / Car lamp
Materiali: Montatura in metallo - Paralume in organza
Materials: Metal frame - Organdie lampshade

TÊTE À TÊTE CL



Lampada da tavolo / *Table lamp*
Materiali: Montatura in metallo - Paralume in organza
Materials: Metal frame - Organzie lampshade

TÊTE À TÊTE LT



Lampada da parete / *Applique*
Materiali: Montatura in metallo - Paralume in organza
Materials: Metal frame - Organzie lampshade

TÊTE À TÊTE AP

Light style

Design: Joe Velluto

NIGHT & DAY

Una elegante sospensione che pur svolgendo la sua abituale funzione nasconde un lato pressoché romantico. Alla sua accensione piccoli punti si illuminano come stelle in un cielo notturno...per trovare anche nel più classico degli oggetti un lato ludico e inaspettato.

A very elegant pendant luminaire with a romantic touch, compact and with a great personality. It looks particularly effective when it is illuminated with a number of small points of LED lights starring the diffuser. Perfect to provide elegance in any place requiring soft and elegant lighting effects.





“Night and day” atmosphere

Sopsensione / Suspension

Materiali: Vetro soffiato nero - Vetro soffiato bianco - Montatura in metallo cromato

Materials: Black blown glass - White blown glass - Chromed metal frame

NIGHT & DAY



Sopsensione / Suspension

Materiali: Vetro soffiato nero - Vetro soffiato bianco - Montatura in metallo cromato

Materials: Black blown glass - White blown glass - Chromed metal frame

“Night” atmosphere

NIGHT & DAY



Sopsensione / Suspension

Materiali: Vetro soffiato nero - Vetro soffiato bianco - Montatura in metallo cromato

Materials: Black blown glass - White blown glass - Chromed metal frame

“Day” atmosphere

NIGHT & DAY

Light style

Design: **Matteo Ragni**

STRIP

Lampada da tavolo in versione contemporanea. Così si potrebbe sintetizzare il concept che ha accompagnato la progettazione di Strip. Da un segno formale seducente, una lama di Corian® che gira su se stessa, lo sviluppo di un corpo che si piega e si posiziona a piacere. Nella versione a parete il tratto curvilineo è l'unico protagonista estetico, con una soluzione originale per l'emissione dei punti luce.

Essentially simple in its conception and geometrically shaped, Strip is extremely versatile as a table or wall luminaire using LED technology. Made of Corian® material, resulting in lightweight lines, where non-essential details disappear and shades get fluid and aerodynamic. It provides an ultra modern and efficient lighting solution to any commercial or home interior.





Lampada da tavolo / *Lampada da tavolo*
Materiali / *Materials*: Corian®

STRIP LT

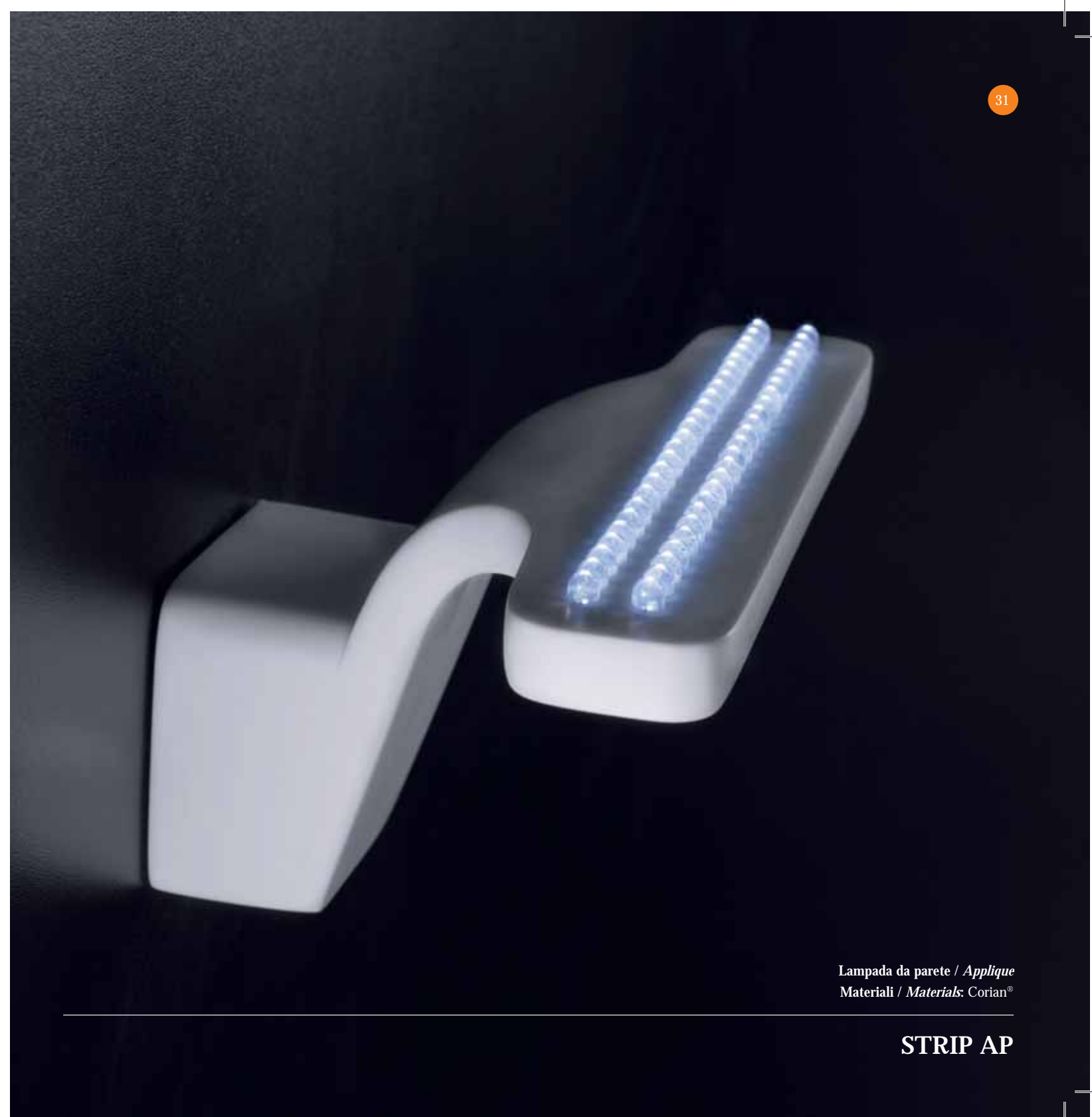

Lampada da parete / *Applique*
Materiali / *Materials*: Corian®

STRIP AP

Light style

Design: Matteo Ragni

SHADOW

É una forma che dialoga con un'icona del paesaggio domestico: l'abat-jour. I materiali e la luce fanno il resto: il diffusore in metacrilato, quando la luce è accesa diventa un pretesto per trasformare Shadow in un oggetto luminoso dalla forte presenza iconica, e il metallo a specchio che trasforma la luce in ombra. Un'ombra che si proietta come un'eclissi lungo i bordi, oppure più lontano, su di un muro.

At first sight it seems to be a classic abat-jour, but soon we realise it is unique and different. The combination of different materials, i.e. metal/mirror and methacrylate, achieves a result that surprises: the light from the diffuser subtly illuminates the perimeter of the mirror creating a warm and pleasant atmosphere, projecting the shadow along the borders and even farther onto the wall.



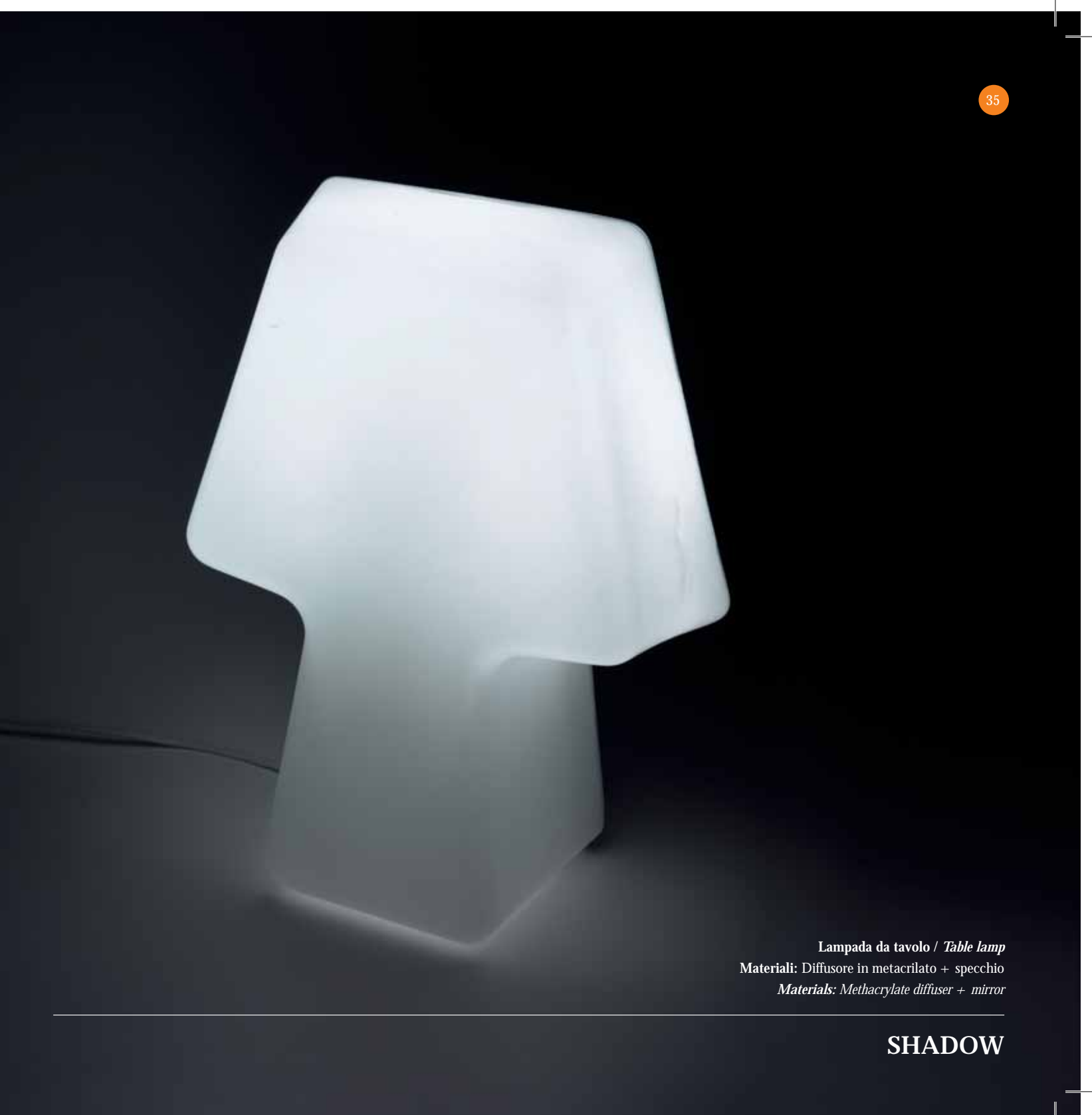

Lampada da tavolo / *Table lamp*
Materiali: Diffusore in metacrilato + specchio
Materials: Methacrylate diffuser + mirror

SHADOW

light style

TECHNICAL DATA

MICRO

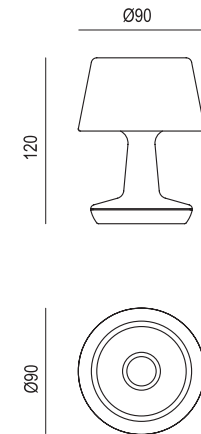

Codice/Code

Materiali/Materials:
Base metallo
Metal base
Diffusore in metacrilato
Methacrylate diffuser

Elettrificazione/Electrics:
1xPower LED Cree 1W



M145.01



Colore/Color:
Base Cromo
Chrome base
Diffusore bianco
White diffuser

M145.02



Colore/Color:
Base Fucsia
Pink base
Diffusore bianco
White diffuser

M145.03



Colore/Color:
Base Verde acido
Acid Green base
Diffusore bianco
White diffuser

M145.04



Colore/Color:
Base Azzurra
Sky blue base
Diffusore bianco
White diffuser

LOFT

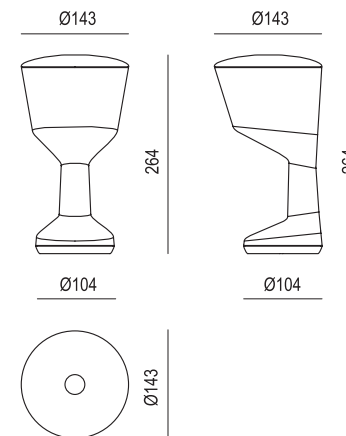

Codice/Code:

Materiali/Materials:
Base metallo
Metal base
Diffusore in metacrilato
Methacrylate diffuser

Elettrificazione/Electrics:
1xE 14 40W



M146.01



Colore/Color:
Base Cromo
Chrome base
Diffusore bianco
White diffuser

M146.02



Colore/Color:
Base Rossa
Red base
Diffusore bianco
White diffuser

M146.03



Colore/Color:
Base bianca
White base
Diffusore giallo
Yellow diffuser

M146.04



Colore/Color:
Base bianca
White base
Diffusore azzurro
Sky blue diffuser

SHOWER LIGHT PT

Codice/Code:

M148.01

M148.02

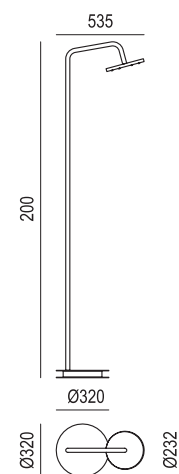

Materiali/Materials:
Metallo
Metal

Elettrificazione/Electrics:
18xPower LEDs Cree 1W



Colore/Color:
Cromo
Chrome



Colore/Color:
Blu*
Blue*

* opzionale - optional

SHOWER LIGHT LT

Codice/Code

M148.05

M148.06

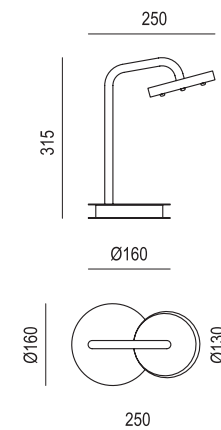

Materiali/Materials:
Metallo
Metal

Elettrificazione/Electrics:
5xPower LEDs Cree 1W



Colore/Color:
Cromo
Chrome



Colore/Color:
Blu*
Blue*

* opzionale - optional

SHOWER LIGHT SO

Codice/Code

M148.03

M148.04

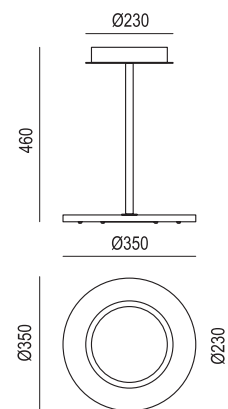

Materiali/Materials:
Metallo
Metal

Elettrificazione/Electrics:
24xPower LEDs Cree 1W



Colore/Color:
Cromo
Chrome



Colore/Color:
Blu*
Blue*

* opzionale - optional

SHOWER LIGHT AP

Codice/Code:

M148.07

M148.08

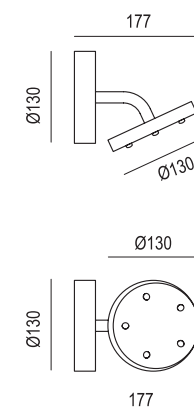

Materiali/Materials:
Metallo
Metal

Elettrificazione/Electrics:
5xPower LEDs Cree 1W



Colore/Color:
Cromo
Chrome



Colore/Color:
Blu*
Blue*

* opzionale - optional

TÊTE À TÊTE CL

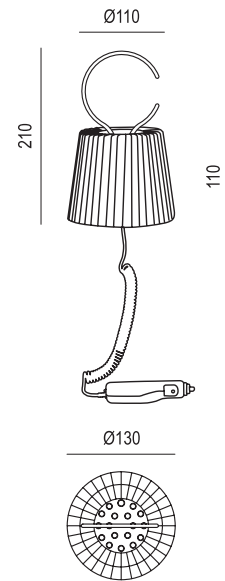

Codice/Code:

M149.01

M149.02

M149.03

M149.04

Materiali/Materials:Gancio in metallo
Metal hookParalume in organza
Organdie lampshade**Elettrificazione/Electrics:**36 LED alta efficienza - 20 mA
36 high efficiency LEDs - 20 mA**Colore/Color:**
Gancio nero
Black hookParalume nero
Black lampshadeLuce bianca
White light**Colore/Color:**
Gancio cromo
Chrome hookParalume bianco
White lampshadeLuce bianca
White light**Colore/Color:**
Gancio cromo
Chrome hookParalume bianco
White lampshadeLuce blu
Blu light**Colore/Color:**
Gancio cromo
Chrome hookParalume bianco
White lampshadeLuce rossa
Red light

TÊTE À TÊTE AP

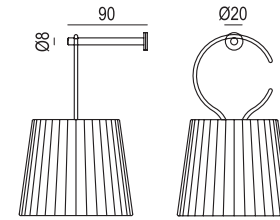

Codice/Code

M149.07

M149.08

M149.09

M149.10

Materiali/Materials:Montatura e gancio in metallo
Metal frame and metal hookParalume in organza
Organdie lampshade**Elettrificazione/Electrics:**36 LED alta efficienza - 20 mA
36 high efficiency LEDs - 20 mA**Colore/Color:**
Montatura e
gancio neri
Black frame
and black hookParalume nero
Black lampshadLuce bianca
White light**Colore/Color:**
Montatura e
gancio cromo
Chrome frame
and chrome hookParalume bianco
White lampshadeLuce bianca
White light**Colore/Color:**
Montatura e
gancio cromo
Chrome frame
and chrome hookParalume bianco
White lampshadeLuce blu
Blu light**Colore/Color:**
Montatura e
gancio cromo
Chrome frame
and chrome hookParalume bianco
White lampshadeLuce rossa
Red light

TÊTE À TÊTE LT

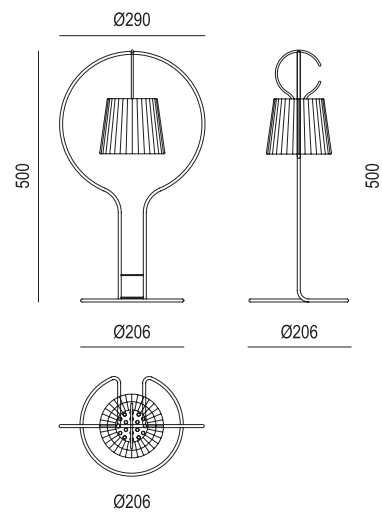

Codice/Code

M149.05

M149.06

Materiali/Materials:Montatura e gancio in metallo
Metal frame and metal hookParalume in organza
Organdie lampshade**Elettrificazione/Electrics:**36 LED alta efficienza - 20 mA
36 high efficiency LEDs - 20 mA**Colore/Color:**
Montatura e
gancio neri
Black frame
and black hookParalume nero
Black lampshadLuce bianca
White light**Colore/Color:**
Montatura e
gancio cromo
Chrome frame
and chrome hookParalume bianco
White lampshadeLuce bianca
White light

NIGHT & DAY

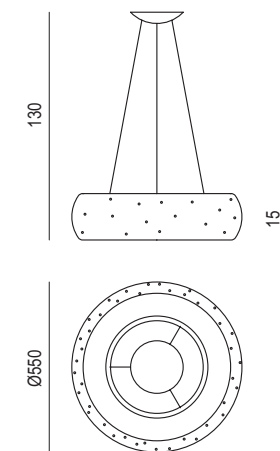

Codice/Code:

M143.01

Materiali/Materials:Vetro soffiato nero - vetro soffiato bianco
Black blown glass - white blown glassMontatura in metallo cromato
Chromed metal frame**Elettrificazione/Electrics:**6xG9 60W + 24 LED alta efficienza - 20 mA
6xG9 60W + 24 high efficiency LEDs - 20 mA

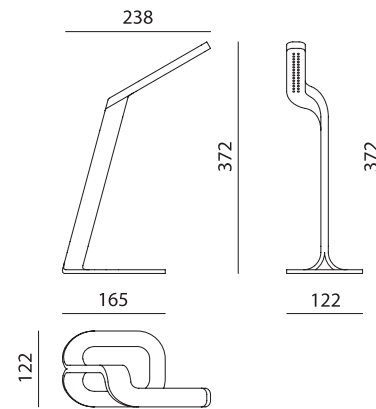
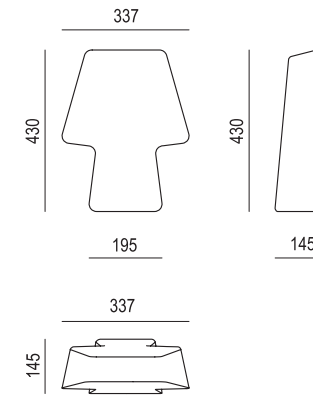
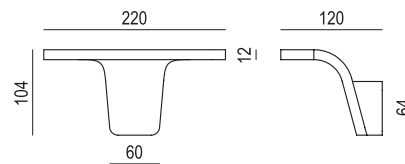
STRIP LT**Codice/Code****M144.01****Materiali/Materials:**
Corian®**Elettrificazione/Electrics:**
30 LED alta efficienza - 20 mA
30 high efficiency LEDs - 20 mA**Colore/Color:**
Bianco
White**SHADOW****Codice/Code****M147.01****Materiali/Materials:**
Diffusore in metacrilato - specchio
Methacrylate diffuser - mirror**Elettrificazione/Electrics:**
1xG13 22W**Colore/Color:**
Bianco
White**STRIP AP****Codice/Code:****M144.02****Materiali/Materials:**
Corian®**Elettrificazione/Electrics:**
50 LED alta efficienza - 20 mA
50 high efficiency LEDs - 20 mA**Colore/Color:**
Bianco
White

light style
COLLECTION



Light style

DESIGNERS



Odoardo Fioravanti

Odoardo Fioravanti nasce a Roma nel 1974.

Laureato in Disegno Industriale presso il Politecnico di Milano, dal 1998 si occupa di industrial design, progettazione grafica e allestimenti. Si è formato collaborando con gli studi Michele De Lucchi Associati, Cibic & Partners, Connexine, Vibram Yellow Tag, Aroundesign (Iacchetti+ Ragni).

Odoardo Fioravanti was born in Rome in 1974.

He graduated in Industrial Design from the Politecnico of Milan. Since 1998 he has worked in the fields of industrial design, graphic design and layouts. His training included working with the following firms: Michele De Lucchi Associati, Cibic & Partners, Connexine, Vibram Yellow Tag and Aroundesign (Iacchetti+ Ragni).



Giulio Iacchetti

Giulio Iacchetti si occupa di industrial design dal 1992. All'attività di progettista alterna l'insegnamento presso numerose università e scuole di design, in Italia e all'estero. È stato insignito con diversi premi internazionali. Con Matteo Ragni nel 2001 si aggiudica il Compasso d'oro con la posata multiuso biodegradabile "Moscardino", oggi parte dell'esposizione permanente del design al MOMA di New York. Per Coop ha ideato il progetto Design alla Coop e attualmente è incaricato del coordinamento del progetto Coop Eureka.

Giulio Iacchetti has been an industrial designer since 1992. He also carries out an intense didactic work for several universities and design schools, in Italy and abroad. He was awarded a number of international prizes. In 2001 his project for a disposable fork "Moscardino" (designed with Matteo Ragni) won the Compasso d'Oro ADI and is now part of the permanent design exhibition at MOMA, New York. For the Italian chain of supermarkets Coop he created the project "Design for Coop" and is now charged of the coordination of the project Coop Eureka.



Joe Velluto

Joe Velluto, studio associato di industrial design e comunicazione dal 2003. Nel Marzo 2005 presenta, presso il Palazzo della Triennale di Milano, il libro "Salefino: nuovi sapori dal design italiano", edito da Editrice Abitare Segesta. Nel 2005, il progetto "RosAria" entra a far parte della collezione permanente di design della "Pinakothek der Moderne" del museo Neue Sammlung di Monaco. Nel 2006 fonda con Cristina Morozzi la "Nazionale Italiana Design".

Joe Velluto, industrial design and communication studio, since 2003.

In March 2005 they introduce the book "Salefino: new flavours from the Italian design", published by Abitare Segesta, at the Triennale Palace of Milan.

In 2005 their project "RosAria" is included in the design permanent collection of "Pinakothek der Moderne" at the Neue Sammlung museum of Munich. In 2006 they found the "Italian Design National Team" with Cristina Morozzi.



Matteo Ragni

Matteo Ragni nasce a Milano nel 1972. Si laurea in architettura al Politecnico di Milano. Dal 1995 si occupa di design. Docente presso la Facoltà del Design al Politecnico di Milano e l'Istituto Europeo di Design, ha tenuto workshop in diverse università del Cile e partecipato a mostre in Italia e Scozia. Dal 1998 al 2005 da' vita con Giulio Iacchetti allo studio Aroundesign ed insieme nel 2001 hanno ricevuto il Compasso d'Oro ADI per la posata multiuso biodegradabile "Moscardino", oggi parte dell'esposizione permanente del design al MOMA di New York.

Matteo Ragni was born in Milan in 1972. He obtained a degree in architecture from the Politecnico of Milan. He has worked in the field of design since 1995. He teaches at the Faculty of Design at the Politecnico of Milan and the Istituto Europeo di Design. He has held workshops at various universities in Chile and taken part in exhibitions in Italy and Scotland. From 1998 till 2005 collaborates with Giulio Iacchetti and with him gives life to the Aroundesign studio. In 2001 their project for a disposable fork "Moscardino" wins the Compasso d'Oro ADI, now part of the permanent design exhibition at MOMA, New York.

Art Direction: JoeVelluto

Testi/Text: Martina Gamboni - Elisa Massoni

Foto/Photo: Florindo Romandini

Foto/Photo pag. 17 + pag. 19: Riccardo Urnato

Visual design: JoeVelluto

Stampa/Print: Chinchio Industria Grafica S.p.A.

Le immagini e i dati riportati in questo catalogo sono indicativi. Ruggiu Srl si riserva il diritto di apportare eventuali variazioni o migliorie agli articoli illustrati, anche senza preavviso. I nostri uffici commerciali rimangono a vostra completa disposizione per qualsiasi ulteriore delucidazione.

The images and the indicated data in our catalogue are approximate. Ruggiu Srl reserves the right to effect any changes or improvements, to the illustrated articles, also without notice. For further information, our trade departments are at your disposal.

Tutte le misure sono espresse in millimetri.

All measures are understood in millimeters.